

AC620 TECH GUIDE

Acoustic aluminium linear slatted ceiling solution

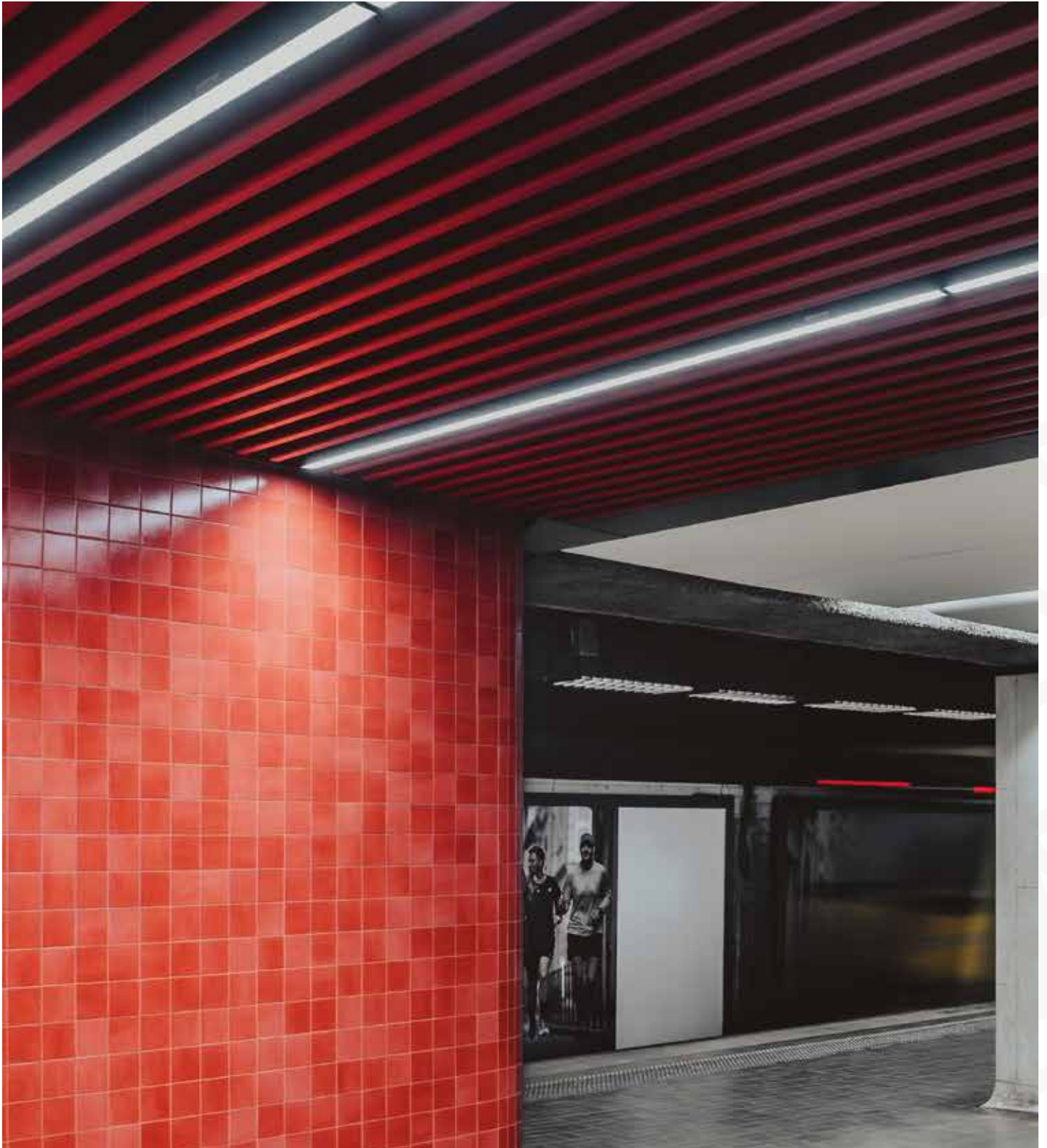

AMRON
ARCHITECTURAL

Product AC620 Acoustic aluminium linear slatted ceiling solution

Features

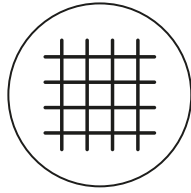

EXPOSED GRID

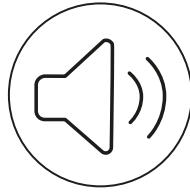

UP TO 1.0 NRC



A2, s1,d0

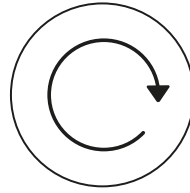

RECYCLABLE

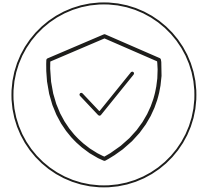

25 YEAR WARRANTY

Grid Steel exposed or concealed grid options

Size 100mm x 25mm, 100mm x 50mm, 150mm x 50mm Standard Slat Sizes. Bespoke sizes on request

Material Aluminium slats, steel infill panels and grid

Mesh Pattern & Types **Applicable only for acoustic infill tiles, which span between battens**
Refer to Mesh Pattern & Types Brochure for specifications

Finish Polyester powder-coated (PPC)
Anodised
Sublimated Timber Effect
Bespoke finishes on request

Acoustic AC700 perforated infill panel with black fleece or 18mm 80kg/m³ density acoustic pad
Absorption: up to 1.0NRC when acoustic infill tiles are installed between battens
Performance is dependent on pattern open area and panel infill

Fire A2, s1,d0 dependant on finish

Environmental ISO 14001 and ISO 9001
Recyclable and designed for disassembly

Technical Services integration supported

Isometric

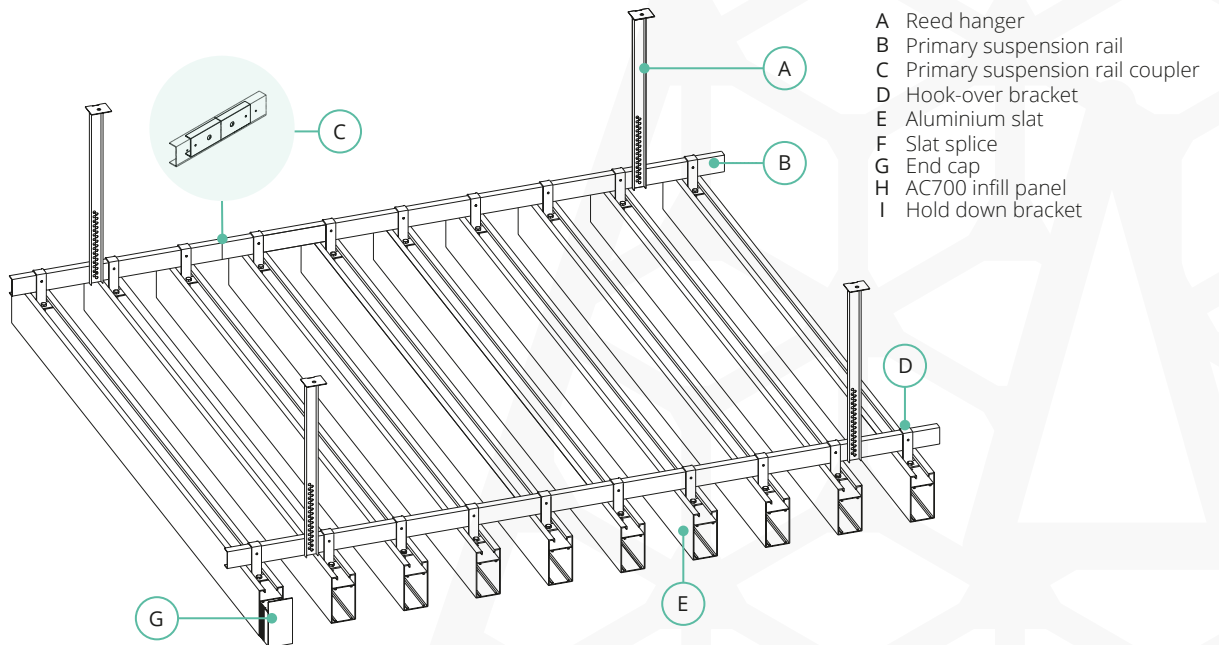

Section - no acoustic infill option

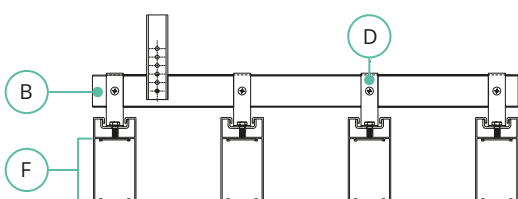

Section - acoustic infill option

